

# Short Logger – 8'

Description: **Reverse Super B**

**DOEPKER**  
INDUSTRIES LTD.

## Trailer Specifications

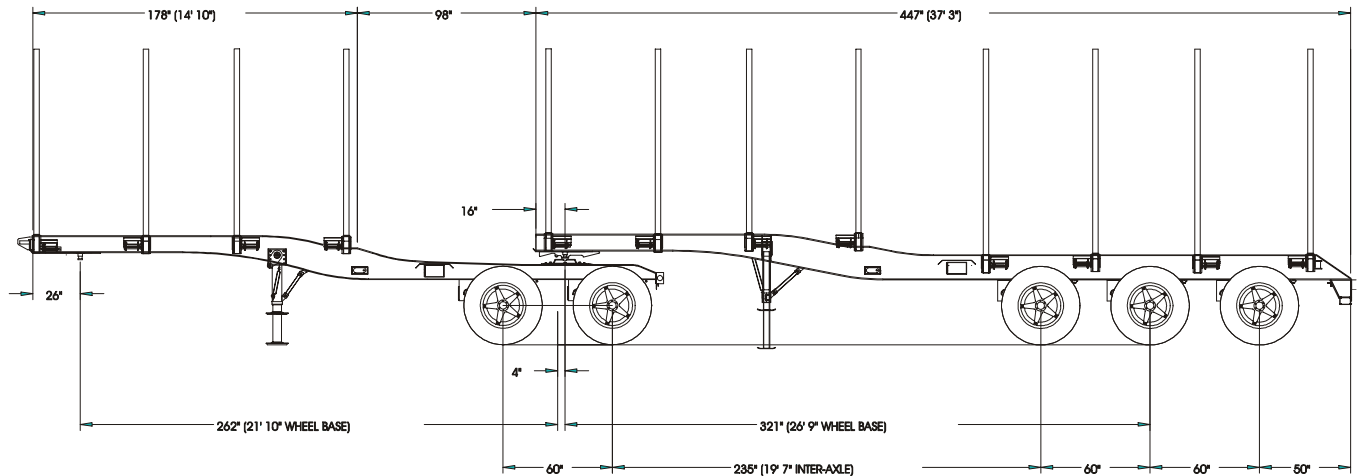

NOTE: 16 x 35'9" model: interaxle and wheelbase measurement 18" shorter on rear. Lead is the same as per drawing above.

LO2001

**Tare Weight:** Upon Request

## Standard Equipment

### Main Beams – Center Rail

Flange and web – T-1 steel with dimensions subject to lengths and ratings

### Winches

- one on each bunk with hook
- turned for easy operation

- \* Mark V, 2-speed landing gear
- \* King pin & 3500 series 5<sup>th</sup> wheel
- \* Coupler plate 1/4"
- \* Mudflaps
- \* Expanded mesh over suspension area
- \* Chain axle slings on all axles

### Lighting

- sealed beam per DOT specs
- cable wiring
- side signal lights
- Brake, side signal, and marker lights are LED
- extra rear signal (red)

### Finish

- fully sand blasted
- PPG high Build Epoxy Primer
- PPG acrylicote - one colour
- reflective tape

### Suspension

- Intraax AA-250 air ride, 25,000 lb. capacity
- 2S1M Anti-lock braking system on each unit
- Stemco seals
- 16 1/2" x 7" P 20-20 linings with dust shields
- 30-30 spring brake
- auto slacks
- 10 stud cast unimount hub and drum
- air system per CMVSS
- 22.5 10 hole steel unimounts – powder coated – white
- 11R 22.5 tubeless radials B.F. Goodrich ST220

### \*Safety Certified