

# Fold Down

Description: **28' x 31' x 8 1/2' Super B**

**DOEPKER**  
INDUSTRIES LTD.

## Trailer Specifications

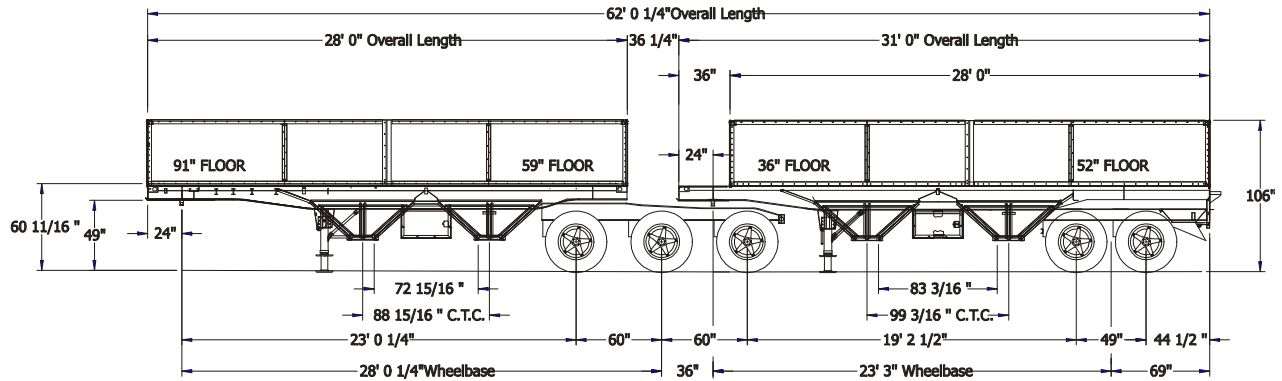

## Standard Equipment

### Capacity

- Lead unit approximately 1100 cu ft
- Rear unit approximately 1250 cu ft

### Height

- 105 1/2" to top of the walls

### Deck Height

- 60 3/4" to top of deck

### Tare Weight

- Including standard equipment approximately 22, 600 lbs

### General

- Main Beam - Outside Rail:
  - 1/4" T1 Web
  - Lower Flange 1/2" x 5" T1, Upper Flange 3x3 tubing c/w 1x2 tubing welded solid
- Aluminum crossmembers, supports and flooring
- Aluminum tarp arches
- Aluminum top caps and wall joiners
- Jost 2 speed landing gear
- Jost king pin at 36" and 24"
- Sealed aluminum tool box on lead trailer
- Inside slopes on front of lead trailer

- Aluminum catwalk front and back

### Walls:

- 3/4" plywood - 48"
- Moisture resistant rubber sealed hinges

### Hoppers:

- 14 gauge pre-painted white aluminum
- 10 gauge steel frame
- Rack & pinion chutes
- 16" x 24" opening
- Removable lid with self cleaning track

### Lighting

- LED lights as per CMVSS
- Side signal lights
- Extra rear signal (red)

### Finish

- Fully sand blasted
- Zinc Rich Primer on outside steel
- PPG High Build Epoxy Primer inside and out
- PPG Acrycote topcoat - one color
- Reflective tape
- Duraguard on rails and below

### Tarp

- Fitted tarp for bulk loads

### Suspension

- Intraax AA-230 air ride 23,000 lbs
- Stemco seals
- 16 1/2" x 7" P20-20 linings with dust shields
- Anti-lock brake system: lead - 2S2M, rear - 2S1M
- Auto slacks
- Air system per CMVSS

### Hubs, Rims & Tires

- 10 stud Cast Unimount hub and drum
- 22.5 - 10 hole steel unimount - powder coated white
- 11R/22.5 tubeless radials B.F. Goodrich ST220

### Protective Features

- Mudflaps full width at landing gear - lead & rear
- Mudflaps at back and chute mudflap for each trailer
- Rear impact guard where required

\* Safety Certified