

Steel Flat Deck - 50 Series

Description: **32' x 28' x 8 1/2' Super B / 28' x 32' x 8 1/2' Super B**

DOEPKER
INDUSTRIES LTD.

Trailer Specifications

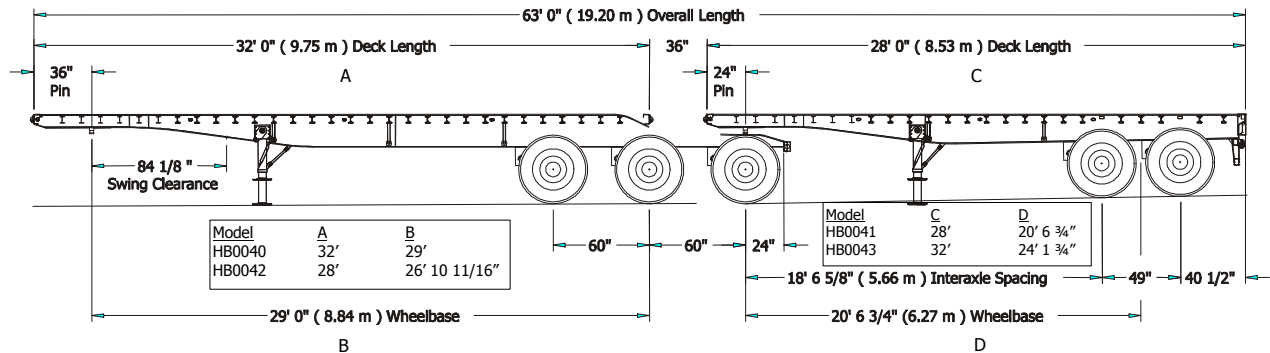

Standard Equipment

Main Rail Ratings

- Distributed Load - approximately 110,000 lbs
- 10' Concentrated Load - approximately 60,000 lbs
- 4' Concentrated Load - approximately 50,000 lbs

Deck Height

- Approximately 58" at front and 53" at back

Tare Weight

- Including standard equipment and winches approximately 20,100 lbs

General

- Main Beams - Center Rail
 - Web: 3/16" high tensile steel
 - Flange: 3/8" x 6" high tensile steel; 1/2" x 6" on bottom of lead
- Crossmembers
 - 4" high tensile Jr. I-beam on 12" centers
- Stake pockets on 4' centers
- Channel rub rail
- Rear bumper - 10 gauge formed panel

- Jost 2 speed landing gear
- Jost king pin at lead - 36", rear - 24"
- Coupler plate 1/4"

Lighting

- LED lights as per CMVSS
- Side signal lights
- Extra rear signal (red)

Decking

- 2" x 6" T & G fir

Finish

- Fully sand blasted steel
- Zinc Rich Primer on complete steel outside
- PPG High Build Epoxy Primer
- PPG Acrycote topcoat - one color
- Reflective tape

Suspension

- Intraax AA-230 air ride - 23,000 lbs
- Stemco seals
- 16 1/2" x 7" P20-20 linings with dust shields
- 30-30 spring brake
- Anti-lock brake system - lead 2S2M; rear 2S1M

- Auto slacks

- Air system per CMVSS

Hubs, Rims & Tires

- 10 stud Cast Unimount hub and drum
- 22.5 - 10 hole steel unimount - powder coated white
- 11R 22.5 tubeless radials Michelin XT-1

Protective Features

- Aluminum checkerplate over center axle of tri group on lead trailer
- Aluminum platform - back of lead
- Mudflaps at back of lead & rear
- Rear impact where required

* Safety Certified