

Tandem 1/4 Frame Gravel Body

Description: **28' x 8 1/2' Tandem**

DOEPKER
INDUSTRIES LTD.

Trailer Specifications

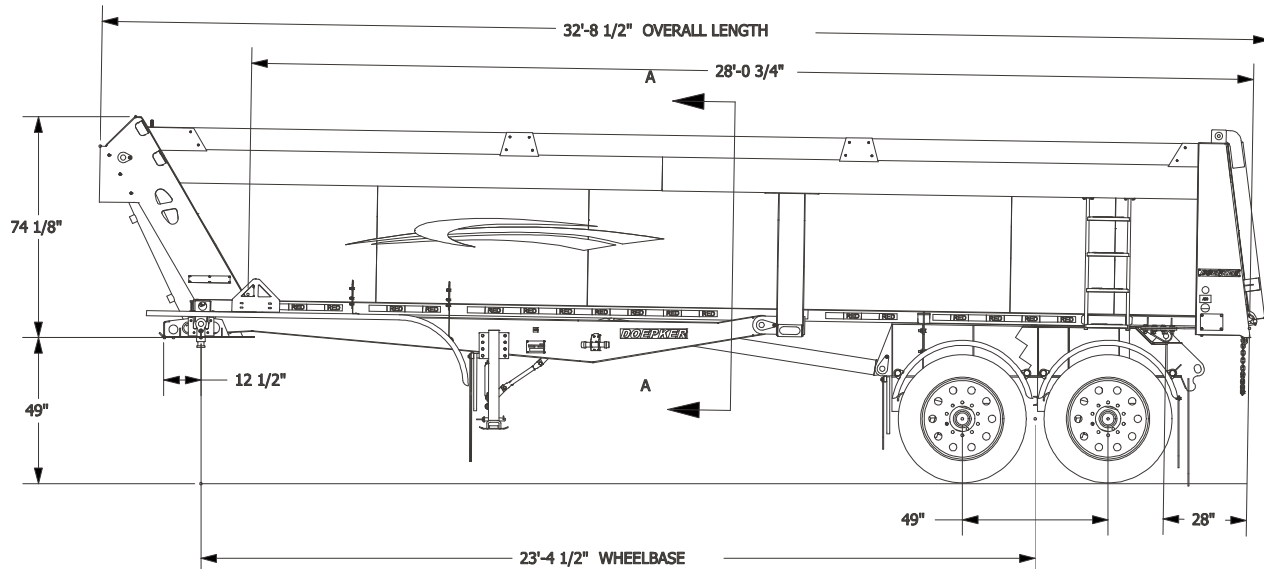

Standard Equipment

Capacity

- 38" wall - approximately 22 1/2 cu.yd.
- 48" wall - approximately 28 1/2 cu.yd.

Tare Weight

- Including standard equipment approximately 15,300 lbs based on a 48" side wall height

General

- D shaped tub style
- Tub - 3/16" AR200
- Extendable drop leg landing gear
- Ladder at back D/S
- Side wall height 38"
- 8" Fir side boards
- External mount hoist - Mailhot 220-8.125-5
- Coupler plate 3/8" oscillating

Lighting

- LED lights as per CMVSS
- Side signal lights
- Extra rear signal (red)

- Side design - SGSV-0
- Back design - SGRV-0
- Turn signal at back raised to center of post

Finish

- Fully sand blasted steel
- Zinc Rich Primer on outside of tub body
- PPG High Build Epoxy Primer
- PPG Acrycote topcoat - two colors
- Decal package
- Reflective tape

Suspension

- Intraax AA-250 air ride 25,000 lbs
- Stemco seals
- 16 1/2" x 7" P20-20 linings with dust shields
- 30-30 spring brake
- 2S1M anti-lock braking system
- Auto slacks
- Air system per CMVSS

Hubs, Rims & Tires

- 10 stud Cast Unimount hub and drum
- 22.5 - 10 hole steel unimount - powder coated white
- 11R 22.5 tubeless radials B.F. Goodrich ST220

Protective Features

- Mudflaps at back
- Galvanized flat fender at front
- Galvanized 1/2 round fender at back
- Mudflaps - full width at landing gear
- Mudflaps - full width in front of suspension
- Mudflaps - full width at back

* Safety Certified