

# Closed End Steel Super B Bulker

Description: **28' x 30' x 8 1/2' Super B / 28' x 31' x 8 1/2' Super B**

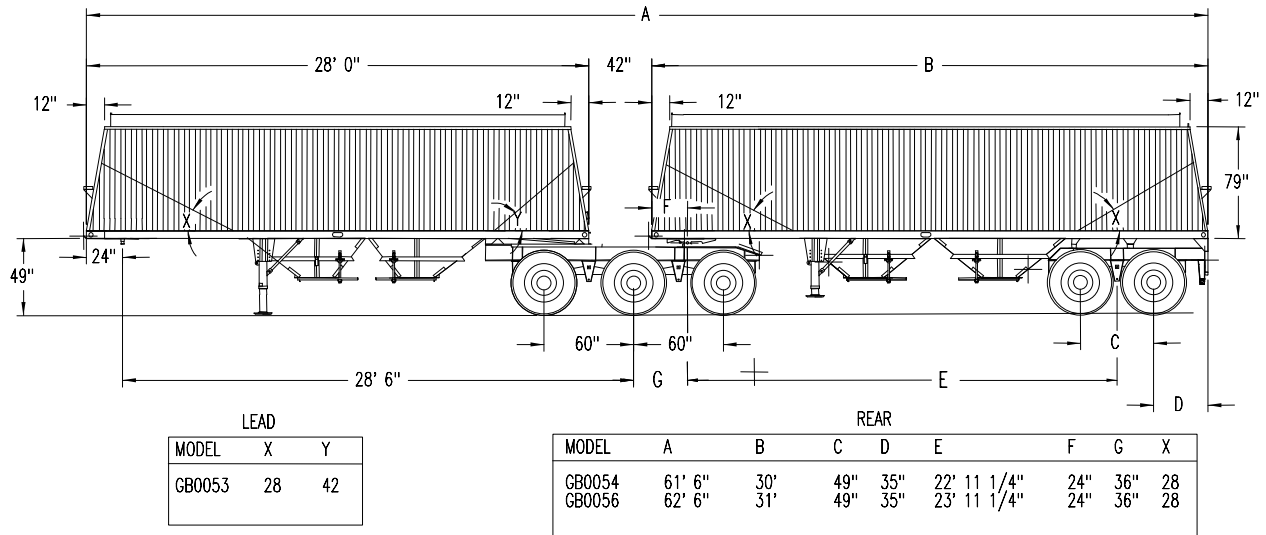

## Trailer Specifications



## Standard Equipment

### Capacity

- Lead unit approximately 1365 cu ft
- 30' rear unit approximately 1450 cu ft
- 31' rear unit approximately 1475 cu ft

### Height

- 136" to top of tarp hood with 79" O/A

### Tare Weight

- 28' x 31' Including standard equipment) approximately 22,800 lbs

### General

- Jost 2 speed landing gear
- Jost king pin at 24"
- Aluminum catwalks and ladders

### Walls:

- Ladders inside
- Walls:
  - 16 gauge steel panel
  - 79" overall wall height
  - 4" vertical corrugations
  - Angled ends

### Hoppers:

- 14 gauge steel
- Rack & pinion chutes
- 16" x 24" openings
- 22" ground clearance

- Removable lid with self cleaning track
- Slopes
  - As per model

### Lighting

- LED lights as per CMVSS
- Side signal lights
- Extra rear signal (red)

### Finish

- Fully sand blasted steel
- Zinc Rich Primer on outside steel
- PPG High Build Epoxy

### Primer inside and out

- PPG Acrycote topcoat - two colors
- Rust check under slopes on seams
- Reflective tape
- Duraguard

### Tarp

- Michel Side Winder
- Short cranks at center
- Welded aluminum hood
- Choice of tarp color
- Reinforcement on all arches
- Tarp vents

### Suspension

- Intraax AA-230 air ride 23,000 lbs
- Stemco seals

- 16 1/2" x 7" P20-20 linings with dust shields
- 30-30 spring brake
- Anti-lock brake system:
  - lead - 2S2M, rear - 2S1M
- Auto slacks
- Air system per CMVSS

### Hubs, Rims & Tires

- 10 stud Cast Unimount hub and drum
- 22.5 - 10 hole steel unimount - powder coated white
- 11R/22.5 tubeless radials B.F. Goodrich ST220

### Protective Features

- Aluminum checkerplate fenders over back two axles of lead trailer
- Mudflaps full width at landing gear - lead & rear
- Mudflaps at back and chute mudflap for each trailer
- Stoneguard brackets
- Rear impact guard where required

\* Safety Certified