

Closed End Commercial Bulker

Description: **42' x 8 1/2' Tridem**

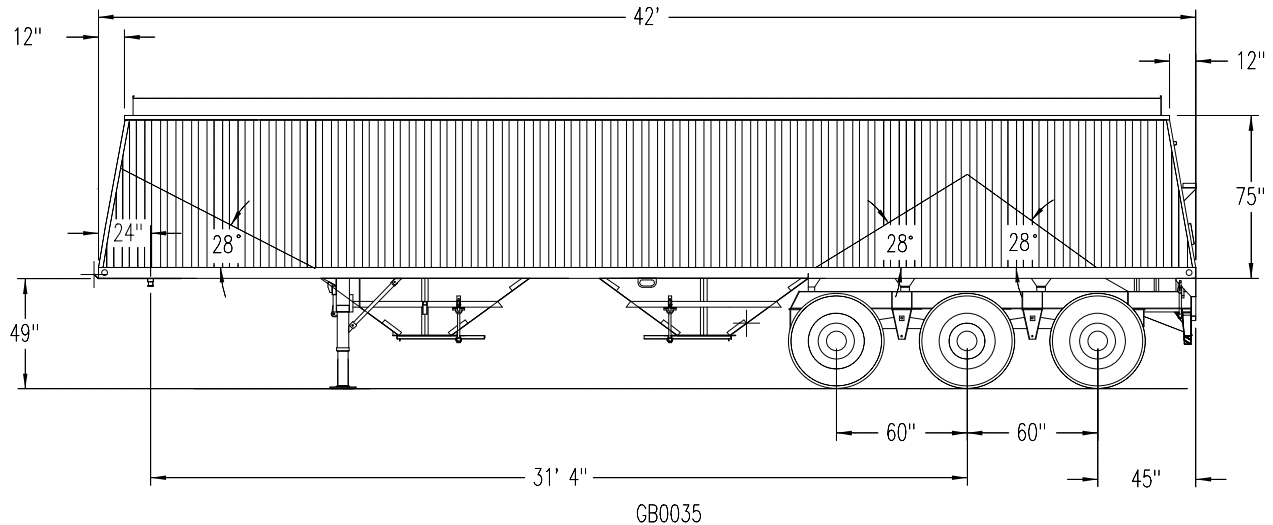

Trailer Specifications



Standard Equipment

- | | | |
|---|---|---|
| <p>Capacity</p> <ul style="list-style-type: none"> - 2150 cu ft <p>Height</p> <ul style="list-style-type: none"> - 132" to top of tarp hood with 75" O/A <p>Tare Weight</p> <ul style="list-style-type: none"> - Including standard equipment approximately 13,800 lbs <p>General</p> <ul style="list-style-type: none"> - Jost 2 speed landing gear - Jost king pin at 24" - Aluminum catwalk and ladder - Ladders inside - Walls: <ul style="list-style-type: none"> - 16 gauge steel panel - 75" overall wall height - 4" vertical corrugations - Angled ends - Hoppers: <ul style="list-style-type: none"> - 14 gauge steel - Rack & pinion chutes - 16" x 24" openings - 22" ground clearance - Removable lid with self cleaning track - Slopes | <ul style="list-style-type: none"> - 16 gauge ribbed <p>Lighting</p> <ul style="list-style-type: none"> - LED lights as per CMVSS - Side signal lights - Extra rear signal (red) <p>Finish</p> <ul style="list-style-type: none"> - Fully sand blasted steel - Zinc Rich Primer on complete steel outside - PPG High Build Epoxy Primer inside and out - PPG Acrycote topcoat - two colors - Rust check under slopes on seams - Reflective tape - Duraguard <p>Tarp</p> <ul style="list-style-type: none"> - Michel Side Winder - Long crank at rear - Welded aluminum hood - Reinforcement on all arches - Choice of tarp color - Tarp vents <p>Suspension</p> <ul style="list-style-type: none"> - Intraax AA-230 air ride 23,000 lbs - Stemco seals | <ul style="list-style-type: none"> - 16 1/2" x 7" P20-20 linings with dust shields - 30-30 spring brake - 2S2M anti-lock braking system - Auto slacks - Air system per CMVSS <p>Hubs, Rims & Tires</p> <ul style="list-style-type: none"> - 10 stud Cast Unimount hub and drum - 22.5 - 10 hole steel unimount - powder coated white - 11R 22.5 tubeless radials B.F. Goodrich ST220 <p>Protective Features</p> <ul style="list-style-type: none"> - Mudflaps full width at landing gear - Mudflaps at back and chute mudflap - Rear impact guard where required <p>* Safety Certified</p> |
|---|---|---|